

LOADABLE MOTOR SYSTEM™ Assembly and Operation Instructions

READ THIS BEFORE YOU BEGIN:

- Study the illustrations and sequence of assembly. **THE SEQUENCE OF ASSEMBLY IS EXTREMELY IMPORTANT. READ ALL INSTRUCTIONS BEFORE USE. USE MR-LMS™ MOTORS AND MOTOR KITS ONLY IN ACCORDANCE WITH ALL INSTRUCTIONS.** Review the parts list and become familiar with all parts before assembly. **IF ANY PARTS ARE MISSING OR DAMAGED, CONTACT RCS AT 1-435-865-7100 OR EMAIL at warranty@aerotech-rocketry.com.**
- **DO NOT USE ANY PARTS OF THE MR-LMS™ SYSTEM THAT ARE DAMAGED IN ANY WAY.** If in doubt, contact RCS at the number above for assistance.
- **DO NOT MODIFY THE MOTOR IN ANY WAY.** Modification of the motor casing or the motor kit parts could result in motor failure, lead to the destruction of both your rocket and motor and may cause personal injury, death and/or property damage. Modification of the motor casing or motor kit in any way will invalidate your motor warranty.
- **DO NOT RE-USE THE MR-LMS™ CASING AFTER FIRING.**
- **USE ONLY AEROTECH/RCS MR-LMS™ MOTOR KITS AND MOTOR PARTS TO LOAD AN MR-LMS™ MOTOR CASING.** The AeroTech/RCS motor kits have been designed specifically for use in your particular AeroTech/RCS MR-LMS™ motor casing. Use of imitation components may destroy your motor, rocket and payload and will invalidate your motor warranty. Only use AeroTech/RCS MR-LMS™ motor kits intended for your specific AeroTech/RCS MR-LMS™ motor casing. **DO NOT INTERCHANGE PARTS!** Do not use AeroTech/RCS MR-LMS™ motor kits or motor components for any other purpose than to load an AeroTech/RCS MR-LMS™ motor casing.
- **DO NOT ATTEMPT TO REUSE ANY OF THE PARTS OF THE MR-LMS™ MOTOR KIT.** These components have been designed for one use only and must be discarded after firing. Reuse can result in motor failure during subsequent operation and will invalidate your motor warranty.
- Read and follow the safety code of the National Association of Rocketry (NAR) and comply with all federal, state and local laws in all activities involving model rockets.

DO NOT OPEN MOTOR KIT UNTIL READY TO USE.

PARTS:

MR-LMS™ MOTOR KIT

MR-LMS™ 29/120 casing	1
Aft propellant grain (two green stripes, one magenta stripe)	1
Forward propellant grain (two green stripes)	1
Liner (3-1/2" long brown paper tube)	1
MR-LMS™ 29mm forward closure	1
Forward insulator (black fiber washer)	1
Delay insulator (13/16" O.D. white paper tube)	1
Delay o-ring (3/32" thick X 13/16" O.D.)	1
RMS-Plus™ delay element (short solid part)	1
Delay spacer (short colored paper ring)	1
Ejection charge container (2-part red plastic cap)	1
Ejection charge retainer cap (red rubber cap)	1
FirstFire Jr.™ igniter	1
Rubber band igniter holder	1
Self-adhesive motor identification label	1

ITEMS NEEDED FOR USE:

- Super Lube™ or other grease
- Hobby knife
- 5-minute epoxy
- Disposable rubber gloves

Chapter 1. Forward Closure Assembly

- 1-1. Apply a light coat of Synco™ Super Lube™ or other grease to the delay o-ring.
- 1-2. **Fig.-1:** Chamfer both inner edges of the delay insulator with your fingernail. Assemble the RMS-Plus™ delay element, delay insulator, delay spacer and delay o-ring as shown.
- 1-3. **Fig.-2:** Apply a light film of grease to the inner circumference of the delay cavity (but not the forward end of the cavity).
- 1-4. **Fig.-3:** Insert the delay charge assembly shown in Fig.-2 into the delay cavity, delay o-ring end first, until it is seated against the forward end of the MR-LMS™ forward closure.

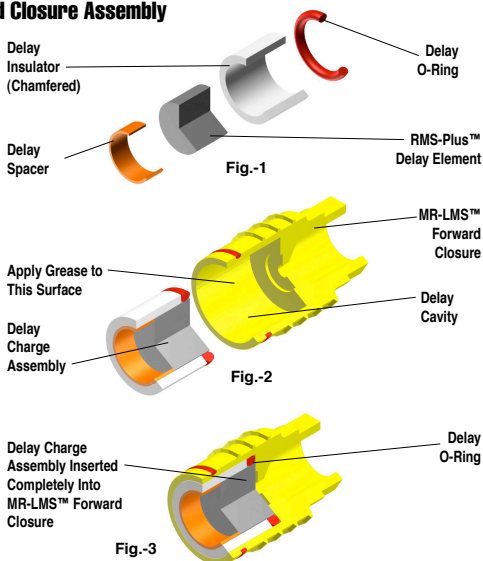

Chapter 2. Case Assembly

- 2-1. **Fig.-4:** Install the propellant grains into the liner. **NOTE:** The use of disposable rubber gloves when handling Mojave Green propellant grains is strongly recommended.
- 2-2. **Fig.-5:** Push the liner assembly into the motor casing until it is seated against the nozzle end of the case. **NOTE:** Place the liner assembly so that the aft propellant grain (two green stripes, one magenta stripe) faces the nozzle.
- 2-3. **Fig.-5:** Install the forward insulator (black fiber washer) into the motor casing until it is seated against the liner assembly.
- 2-4. **Fig.-5:** Mix about 5 grams of a good-quality 5-minute epoxy. Apply a liberal coat of epoxy to the inside surface of the casing in the threaded area above the liner assembly. **CAUTION:** Do not allow epoxy to contact the propellant grain surface.
- 2-5. **Fig.-6:** Apply a liberal coat of epoxy to the threaded area of the previously assembled forward closure assembly. **CAUTION:** Do not allow epoxy to contact the delay grain surface. With the motor casing held in a horizontal position, thread the forward closure assembly into the open end of the motor casing by hand until it is seated against the forward insulator. Apply additional epoxy to the joint between the forward closure and the case. Set the completed assembly aside to cure in a vertical position.

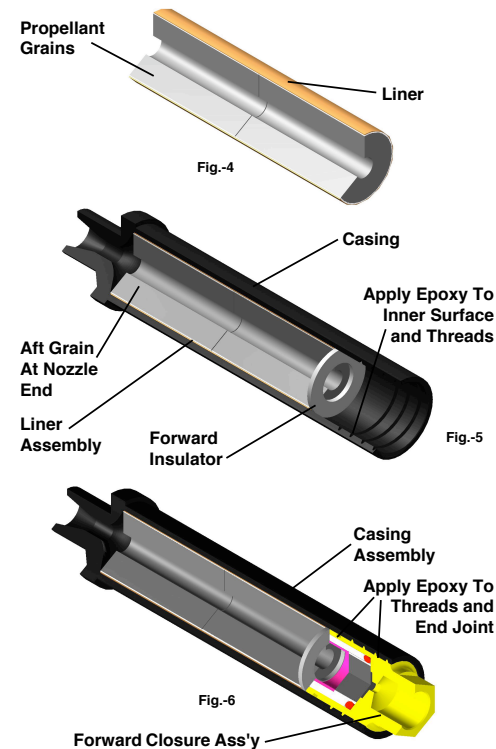

Chapter 3. Ejection Charge Installation

- 3-1. **Fig.-7:** Carefully open the ejection charge container (2-piece red plastic cap) and dispense the ejection charge into the ejection charge well of the forward closure.
- 3-2. **Fig.-8:** Press the ejection charge cap (red rubber cap) into the ejection charge well.
- 3-3. **Fig.-8:** Release the air trapped under the cap by puncturing the center of the cap using the sharp point of a hobby knife.
- 3-4. **Fig.-8:** With the motor held in a **NOZZLE DOWN** position, gently shake the motor to settle the ejection charge into the cavity above the delay element.
- 3-5. Apply self-adhesive label to case to identify motor type and delay. **NOTE:** The motor may be fired as soon as the bulkhead epoxy has solidified.

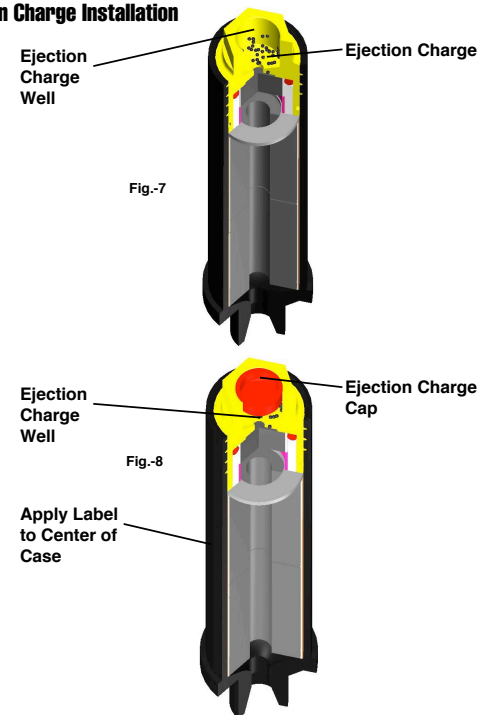

Chapter 4. Preparation For Flight

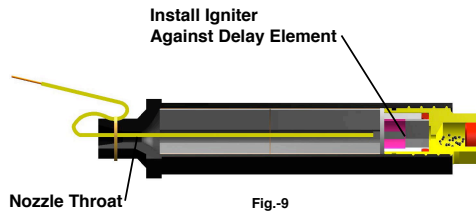

Fig-9

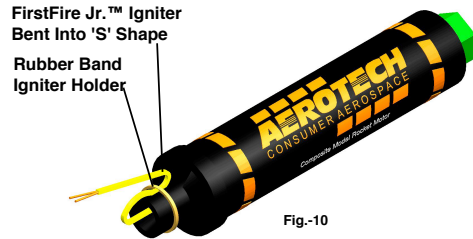

Fig-10

4-1. **Fig.-9:** Insert the coated end of the FirstFire Jr.™ igniter through the nozzle throat until it stops against the delay element.

4-2. **Fig.-10:** Bend the exposed end of the igniter into an 'S' shape as shown. Place the rubber band over the nozzle extension to secure the igniter to the motor.

4-3. Install the motor into the rocket's motor mount tube. Ensure that the motor is securely retained in the rocket by using positive mechanical means to prevent it from being ejected at the time of ejection charge firing. **NOTE:** When using MR-LMS™ motors to launch an AeroTech rocket kit, use the appropriate spacer tubes and ensure that the motor clip snaps into one of the slots in the nozzle end of the motor casing and the motor clip firmly locks the motor into place.

4-4. Prepare the rocket's recovery system and then launch the rocket in accordance with the National Association of Rocketry (NAR) Safety Code and National Fire Protection Association (NFPA) Code 1122.

Chapter 5. First Aid

DANGER: DO NOT INGEST PROPELLANT OR BREATHE EXHAUST FUMES! WASH HANDS AFTER HANDLING MOJAVE GREEN PROPELLANT AND BEFORE EATING. For a minor burn, apply a burn ointment. For a severe burn, immerse the burned area in ice water at once and see a physician as quickly as possible. In the unlikely event of oral ingestion of the propellant, induce vomiting and see a physician as quickly as possible. Mojave Green composite propellant consists primarily of Ammonium Perchlorate, Barium Nitrate and a rubber-like plastic elastomer.

Chapter 6. Disposal

Damaged or defective MR-LMS™ motor kits should be returned to RCS.

Chapter 7. Fire Safety

Tests show that the pyrotechnic components of MR-LMS™ motor kits will not explode in fires and normally will not ignite unless subjected to direct flame and then will burn slowly. Use water to fight any fires in which AeroTech/RCS MR-LMS™ motor kit pyrotechnic components may become involved: Direct the water at the AeroTech/RCS MR-LMS™ motor kit pyrotechnic components to keep them below their 550 deg. F autoignition temperature. Foam and carbon dioxide fire extinguishers will NOT extinguish burning propellants of the type used in MR-LMS™ motor kit pyrotechnic components. Keep motor kit pyrotechnic components away from flames, sources of heat and flammable materials.

Disclaimer and Warranty

NOTICE: As we cannot control the storage and use of our products, once sold we cannot assume any responsibility for product storage, transportation or usage. RCS shall not be held responsible for any personal injury or property damage resulting from the handling, storage or use of our product. The buyer assumes all risks and liabilities therefrom and accepts and uses AeroTech/RCS products on these conditions. No warranty either expressed or implied is made regarding AeroTech/RCS products, except for replacement or repair, at RCS's option, of those products which are proven to be defective in manufacture within one year from the date of original purchase. For repair or replacement under this warranty, please contact RCS. Proof of purchase will be required. Note: Your state may provide additional rights not covered by this warranty.

AEROTECH
CONSUMER AEROSPACE

Division of RCS Rocket Motor Components, Inc.



Advanced Delay Sealing System

MODEL ROCKET LMS™

Loadable Motor System™

MR-LMS™ 29/120

MOJAVE GREEN™ PROPELLANT

**DO NOT OPEN
MOTOR KIT
UNTIL READY
TO USE**

THIS PACKAGE CONTAINS ONE MR-LMS™ MOTOR KIT:

G78-4G/L

G78-7G/L

G78-10G/L

NOTE: To change delays, use AeroTech Reload Delay Kits (RDKs). For 4 second delay times, use RDK-38 Plus (.283" delay, .438" silver spacer). For 7 second delay times, use RDK-02 Plus (.375" delay, .344" red spacer). For 10 second delay times, use RDK-04 Plus (.469" delay, .250" orange spacer).

Maximum recommended lift-off weights: G78-4G/L = 52 oz. (1474 grams), G78-7G/L = 32 oz. (907 grams), G78-10G/L = 20 oz (567 grams)

NOTE: SALE TO PERSONS UNDER 18 YEARS OF AGE PROHIBITED BY FEDERAL LAW. DANGER-POISON: Contains Barium Nitrate. DO NOT INGEST PROPELLANT OR BREATHE EXHAUST FUMES. WARNING-FLAMMABLE: Read Instructions Before Use. KEEP OUT OF REACH OF CHILDREN. FOR USE ONLY BY INDIVIDUALS 18 YEARS OF AGE OR OLDER. DO NOT SMOKE when loading these motors or use in the vicinity of open flames.

Typical Time-Thrust Curve:

Certified by the National Association of Rocketry

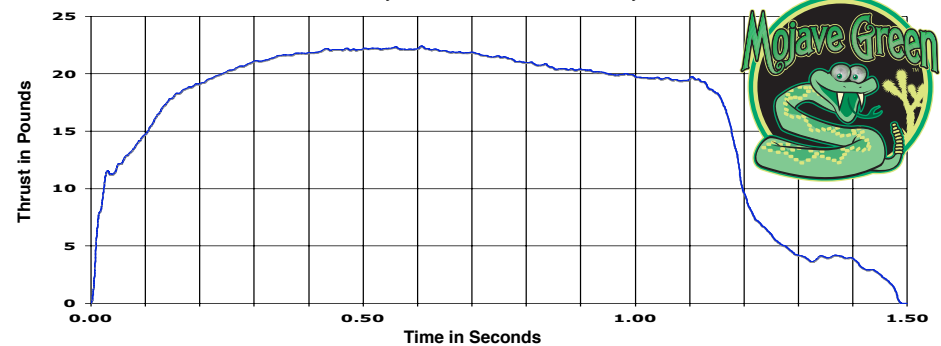

MR-LMS™ 29/120 MOJAVE GREEN MOTOR KIT DATA

Casing Desig.	Performance Desig.	Total Impulse (Max.)	Propellant Wt.	Loaded Motor Wt.
MR-LMS™ 29/120	G78G/L	112 N-sec	59.7 g (0.131 lb)	128 g (0.282 lb)

MR-LMS™ 29/120 CASING DATA

Casing Designation	Motor Diameter	Motor Length	Casing Weight	Motor Kit Used
MR-LMS™ 29/120	1.125" (29mm)	4.875"	49 g (0.108 lb)	G78G/L